













Automatische Mess- und Steuerungstechnik GmbH

# Medium Voltage Transformers

We make energy measurable



# Our Product Range

	Analogue measuring instruments
	Digital measuring instruments
	Electricity meters
	Current transformers
	Measurement transducers
	Shunts
	Gas warning systems for campervan, caravan, truck
	Gas warning systems for private household
	Miniature indicators
	Grid plug-in elements
	Switch position indicators
	Special instruments for rail operation

# OVERVIEW

**Current transformers – technical terms**

**from page 4**

## Medium voltage transformers for indoor application



Support type current transformer

7.2 kV; 12 kV; 17.5 kV – up to 12 kV available with PTB design permit  
narrow design according to DIN 42600, part 8

page 8



Support type current transformer, primary reversible

7.2 kV; 12 kV; 17.5 kV – up to 12 kV available with PTB design permit  
narrow design according to DIN 42600, part 8

page 10



Support type current transformer

7.2 kV; 12 kV; 17.5 kV – up to 12 kV available with PTB design permit  
wide design

page 12



Support type current transformer

24 kV – available with PTB design permit  
narrow design according to DIN 42600, part 8

page 14

## Split core current transformer in full encapsulation for indoor application



Two-part split core current transformer  
0.72 kV / 1.2 kV

page 16

## Single-pole and double-pole insulated medium voltage transformer for indoor application



Voltage transformer

7.2 kV; 12 kV; 17.5 kV; 24 kV – available with BTP design permit  
narrow, small and large design according to DIN 42600, parts 7 or 3

page 18

# Technical Terms

Current transformers are special transformers for the proportional conversion of currents with high current intensities to directly measurable, small values. Conditioned by their constructive design, as well as their physical operating principle, a safe, galvanic separation between primary circuit and measuring circuit is obtained.

<b>Primary rated current</b>	Value of the primary current, tagging the current transformer and for which it is rated.
<b>Secondary rated current</b>	Value of the secondary current, tagging the current transformer and for which it is rated.
<b>Rated conversion</b>	Proportion of the primary rated current to the secondary rated current. A transformers measurement conversion is indicated as full fraction on the nameplate.
<b>Load resistance</b>	Impedance of the secondary circuit, expressed in Ohm with indication of the performance factor.
<b>Rated burden</b>	Value of the load resistance, based on the transformers accuracy specifications.
<b>Rated power</b>	Value of the output power (in [VA] at designated power factor), which can be released by the transformer to the secondary circuit at secondary rated current and rated burden.
<b>Rated frequency</b>	Value of the frequency, on which the transducer's measurement is based.
<b>Accuracy class</b>	Specification for a current transformer, whose measurement deviations under compulsory application conditions, are within determined limits.
<b>Phase displacement [<math>\Delta\phi</math>]</b>	Angle difference between the primary current and the secondary current. Though, the direction of the circuits is selected in such a way, that in case of an ideal current transformer, the phase displacement is equal to zero.
<b>Current measuring deviation (conversion error)</b>	Current measurement deviations, caused by a transformer during the measurement of a current and which result from a deviation of the rated conversion. The current measurement deviation expressed in percent, is calculated according to the following formula:

$$F_i [\%] = \frac{(K_n I_s - I_p) \times 100}{I_p}$$

$F_i$  = Current measurement deviation in %  
 $K_n$  = Nominal conversion  
 $I_p$  = Actual primary current  
 $I_s$  = Actual secondary current, if  $I_p$  flows under measurement conditions.

<b>Highest voltage for equipment <math>U_m</math></b>	Effective value (kV) of the highest phase-to-phase voltage, for which a transformer is rated in respect to its insulation.
---	--

# Technical Terms

## Overall measurement deviation

In stationary state the effective value of the difference between:

- The instantaneous value of the primary current and
- The instantaneous values of the actual secondary current, multiplied by the measurement conversion, where the positive signs of the primary and secondary currents correspond to the arrangement for the connector markings.

The overall measurement deviation  $F_G$  is generally calculated in percent of the primary current's effective values according to the following formula:

$$F_G = \frac{100}{I_p} \times \sqrt{\frac{1}{T} \times \int_0^T (K_n i_s - i_p)^2 dt}$$

$K_n$  = rated conversion  
 $I_p$  = effective value of the primary current  
 $i_p$  = instantaneous value of the primary current  
 $i_s$  = instantaneous value of the secondary current  
 $T$  = period duration

## Rated- / limiting current [ $I_{pl}$ ]

Value of the lowest primary current, for which the transformers overall measurement deviation is equal or greater than 10 % at secondary rated burden.

## Overcurrent limitation factor (FS)

Proportion of the rated-limiting current to the primary rated current.

## Rated thermal continuous current [ $I_{cth}$ ]

Value of the continuous current in the primary winding, for which the overheating does not exceed the value determined in the standard, where the secondary wiring is loaded with the rated burden.

## Rated thermal short-time current [ $I_{th}$ ]

Effective value of the primary current, to which the transformer resists undamaged for the period of 1 second at short-circuited.

## Rated pulse current [ $I_{dyn}$ ]

Peak value of the primary current, to whose electromagnetic effect the current transformer resists without any electrical or mechanical damage short-circuited at secondary wiring.

## "Open voltage" of current transformers

**For security reasons, current transformers, which are not directly connected to a consumer, must be short-circuited on the secondary side!**

A current transformer operated accessible on the secondary side, induces very high peak values on its secondary terminals. The absolute values of these voltages can, dependent on the sizing of the current transformer, reach values of up to several kilovolts and consequently signify a danger to people and the functional reliability of the transformer.

## Earthing of the secondary terminals

According to DIN VDE 0141 (01/2000) paragraph 5.3.4, current transformers and voltage transformers for nominal voltages from  $U_m = 3.6$  kV must be earthed on the secondary side. The implementation of the earth connections is compulsory beginning from the 10N series.

# Technical Terms

## Error thresholds for transformers of the classes 0.2...3 according to DIN EN 61869, Part 1 + 2 (formerly DIN EN 60044-1)

accuracy class	current error $\pm \Delta_F$ at					phase displacement $\pm \Delta_F$ at				
	$1.2 I_n$ $1.0 I_n$	$0.5 I_n$	$0.2 I_n$	$0.05 I_n$	$0.01 I_n$	$1.2 I_n$ $1.0 I_n$	$0.5 I_n$	$0.2 I_n$	$0.05 I_n$	$0.01 I_n$
	%	%	%	%	%	min	min	min	min	min
0.2S	0.2		0.2	0.35	0.75	10		10	15	30
0.2	0.2		0.35	0.75		10		15	30	
0.5S	0.5		0.5	0.75	1.5	30		30	45	90
0.5	0.5		0.75	1.5		30		45	90	
1	1		1.5	3		60		90	180	
3	3	3								

## Error thresholds of the protective current transformers

accuracy class	current error $\pm F_i$ at		phase displacement $\pm F_i$ at	
	1.0 $I_n$ and nominal thermal continuous current		1.0 $I_n$ and nominal thermal continuous current	
	%		minutes	
5 P ...	1		60	
10 P ...	3			

Total error  $F_g$  at nominal error limit current and nominal loads class 5P ...  $\leq 5\%$   
class 10P ...  $\leq 10\%$

## Partial discharges

Requirements for partial discharges are valid for transformers with  $U_m \geq 7.2$  kV.

### Test voltages for partial discharges and permissible levels

type of system earthing	test voltage for partial discharge (effective value) kV	permissible level of partial discharge <sup>2)</sup> pC	
		type of insulation	
		fluid-immersed	solid material
neutral point earthed <sup>1)</sup> (earth fault factor $\leq 1.5$ )	$U_m$ $1.2 U_m / \sqrt{3}$	10 5	50 20
neutral point insulated or not actively earthed <sup>1)</sup> (earth fault factor $> 1.5$ )	$1.2 U_m$ $1.2 U_m / \sqrt{3}$	10 5	50 20

- 1) If the type of the system earthing is not indicated, the values for the insulated or inactively earthed neutral point are valid.  
2) The permissible level for partial discharge is also valid for the frequencies deviating from the rated frequency

# Technical Terms

## Designations of the transformers connection terminals

The connections of all primary windings are designated „P1“and „P2“, the connections of all secondary windings are designated with the corresponding lower case letters „s1“ and „s2“.

## Power consumption of measurement arrangements

During usage of current transformers, the following two principal claims are made by the operator:

- high measurement accuracy within nominal current range
- protective function within overcurrent range

For the implementation of these requests, it is necessary to adapt the tender (the nominal output power) of the current transformer to the actual power requirement of the measurement arrangement.

Apart from the internal power consumption of the connected measuring devices, the conduction losses of the connections to the transformers secondary circuit must be considered, in order to ascertain the actual power requirement.

See the respective data sheets for the actual power requirement of the connected measuring devices.

**Take note:** If the power requirement of the measuring arrangement is considerably lower than the current transformers tender, it consequently will lose its protective function within the overcurrent range. In an extreme case this can lead to a malfunction of the connected measuring devices.

## Internal consumption of copper wires

$$P_v = \frac{I_s^2 \times 2 \times l}{A_{cu} \times 56} \text{ VA}$$

$I_s$  = secondary rated current [A]  
 $l$  = cable length in m  
 $A_{cu}$  = wire cross-section in mm<sup>2</sup>  
 $P_v$  = power loss of the connector cables

NOTE: for consolidated return lines of three-phase alternating current, half of the  $P_v$  values are valid.

**Table for values related to 5 A**

cross-section	1 m	2 m	3 m	4 m	5 m	6 m	7 m	8 m	9 m	10 m
2.5 mm <sup>2</sup>	0.36	0.71	1.07	1.43	1.78	2.14	2.50	2.86	3.21	3.57
4.0 mm <sup>2</sup>	0.22	0.45	0.67	0.89	1.12	1.34	1.56	1.79	2.01	2.24
6.0 mm <sup>2</sup>	0.15	0.30	0.45	0.60	0.74	0.89	1.04	1.19	1.34	1.49
10.0 mm <sup>2</sup>	0.09	0.18	0.27	0.36	0.44	0.54	0.63	0.71	0.80	0.89

**Table for values related to 1 A**

cross-section	10 m	20 m	30 m	40 m	50 m	60 m	70 m	80 m	90 m	100 m
1.0 mm <sup>2</sup>	0.36	0.71	1.07	1.43	1.78	2.14	2.50	2.86	3.21	3.57
2.5 mm <sup>2</sup>	0.14	0.29	0.43	0.57	0.72	0.86	1.00	1.14	1.29	1.43
4.0 mm <sup>2</sup>	0.09	0.18	0.27	0.36	0.45	0.54	0.63	0.71	0.80	0.89
6.0 mm <sup>2</sup>	0.06	0.12	0.18	0.24	0.30	0.36	0.42	0.48	0.54	0.60
10.0 mm <sup>2</sup>	0.04	0.07	0.11	0.14	0.18	0.21	0.25	0.29	0.32	0.36

# Support Type Current Transformers

## Support type current transformers for indoor application

7.2 kV, 12 kV and 17.5 kV – narrow design according to DIN 42600, part 8  
7.2 kV and 12 kV available with PTB design permit and legalization



### Description:

Medium voltage current transformers for indoor applications, which transmit one or several network side originating primary currents into standardised secondary currents in a proportional and phase preserving way. They are encapsulated in polyurethane resin and apart from their primary function as transformer they also serve as collective rail holder.

These current transformers are applicable for measuring purposes as well as for protective purposes; optionally permitted up to 12 kV according to the conformity evaluation procedure for billing purposes.

The medium voltage current transformers are also available as multicore transformers. The possible maximum number of cores depends on the chosen power and accuracy class, which result in the core volume.

### Technical data:

	(E)CTS7,2M11	(E)CTS12M11	CTS17,5M11
Max. operating voltage $U_m$ :	7.2 kV	12 kV	17.5 kV
Rated power frequency withstand voltage:	20 kV	28 kV	38 kV
Rated lightning impulse withstand voltage:	60 kV	75 kV	95 kV
Nominal therm. continuous current $I_{ctn}$ :	$1.2 \times I_N$	$1.2 \times I_N$	$1.2 \times I_N$
Nominal therm. short-time current $I_{th}$ :	$100 \times I_N$ , 1 sec.; max. 31.5 kA, 1 sec.	$100 \times I_N$ , 1 sec.; max. 31.5 kA, 1 sec.	$100 \times I_N$ , 1 sec.; max. 31.5 kA, 1 sec.
Rated pulse current $I_{dyn}$ :	$2.5 \times I_{th}$	$2.5 \times I_{th}$	$2.5 \times I_{th}$
Primary nominal current:	25 A – 2500 A	25 A – 2500 A	25 A – 2500 A
Secondary nominal current:	5 A or 1 A	5 A or 1 A	5 A or 1 A
Nominal frequency:	50 / 60 Hz	50 / 60 Hz	50 / 60 Hz
Transformer accuracy classes:	1; 0.5; 0.5S; 0.2; 0.2S	1; 0.5; 0.5S; 0.2; 0.2S	1; 0.5; 0.5S; 0.2; 0.2S
Optionally for billing purposes:	yes	yes	no
protection current transformer accuracy classes:	5P5; 5P10; 5P20; 5P30; 10P5; 10P10; 10P20; 10P30	5P5; 5P10; 5P20; 5P30; 10P5; 10P10; 10P20; 10P30	5P5; 5P10; 5P20; 5P30; 10P5; 10P10; 10P20; 10P30
Insulation class:	E	E	E
Cantilever strength:	5000 Nm	5000 Nm	5000 Nm
Weight:	approx. 22 kg	approx. 22 kg	approx. 22 kg

Technical amendments reserved Please note, that the above entries are standard values. Deviating values upon request.



## Dimensional drawings:

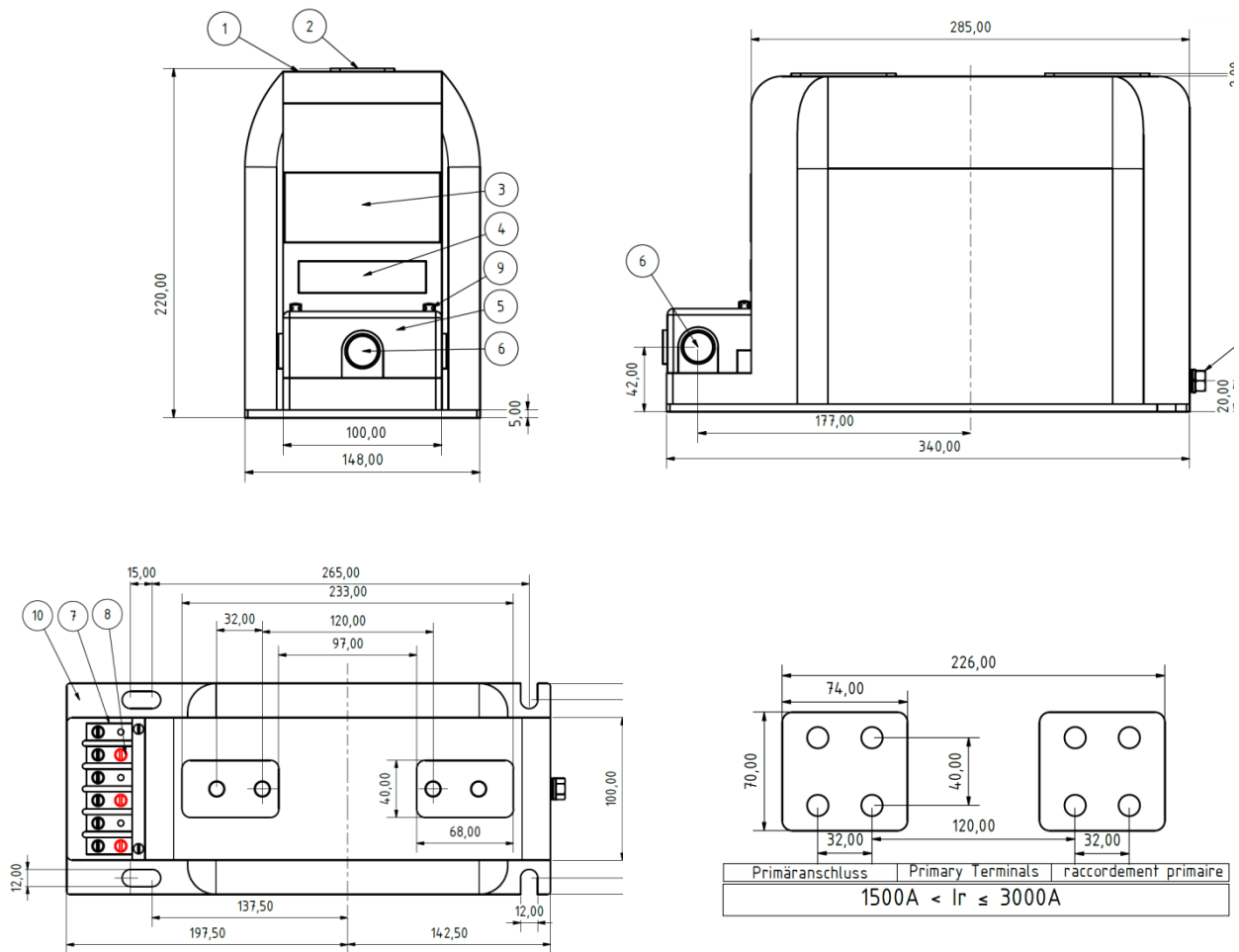

## Key:

1	Resin body
2	Primary connection M12x23, screws M12x25 (annotation: primary connections also available with a hole interval of 40mm instead of 32 mm)
3	Power rating plate
4	Warning plate
5	Transparent terminal box cover
6	Cable bushing PG16 (annotation: cable bushing also available with M20x1.5 screw thread upon request.)
7	Max. 6 clamps M5x10, screws M5x12
8	Secondary earth screw, red, M5x15
9	Fastening screws for terminal box cover (sealable for versions approved for billing purposes)
10	Base plate
11	Rear ground connector M8x16

# Support Type Current Transformers

**Primary reversible support type current transformer for indoor application**  
 7.2 kV, 12 kV and 17.5 kV – narrow design according to DIN 42600, part 8  
 7.2 kV and 12 kV available with PTB design permit and legalization



## Description:

Medium voltage current transformers for indoor applications, which transmit one or several network side originating primary currents into standardized secondary currents in a proportional and phase preserving way. They are encapsulated in polyurethane resin and apart from their primary function as transformer they also serve as collective rail holder.

These current transformers are applicable for measuring purposes as well as for protective purposes; optionally permitted up to 12 kV according to the conformity evaluation procedure for billing purposes.

The medium voltage current transformers are also available as multicore transformers. The possible maximum number of cores depends on the chosen power and accuracy class, which result in the core volume.

For primary reversible transformers, the possibility of choosing between two primary nominal voltages by means of parallel or series circuit exists, depending on terminal of the primary connection.

The primary nominal currents can only be implemented at a ratio of 1:2.

## Technical data:

	(E)CTS7,2M11U	(E)CTS12M11U	CTS17,5M11U
Max. operating voltage $U_m$ :	7.2 kV	12 kV	17.5 kV
Rated power frequency withstand voltage:	20 kV	28 kV	38 kV
Rated lightning impulse withstand voltage:	60 kV	75 kV	95 kV
Nominal therm. continuous current $I_{cth}$ :	$1.2 \times I_N$	$1.2 \times I_N$	$1.2 \times I_N$
Nominal therm. short-time current $I_{th}$ :	$100 \times I_N$ , 1 sec.; max. 31.5 kA, 1 sec.	$100 \times I_N$ , 1 sec.; max. 31.5 kA, 1 sec.	$100 \times I_N$ , 1 sec.; max. 31.5 kA, 1 sec.
Rated pulse current $I_{dyn}$ :	$2.5 \times I_{th}$	$2.5 \times I_{th}$	$2.5 \times I_{th}$
Primary nominal current:	2x25 A – 2x600 A	2x25 A – 2x600 A	2x25 A – 2x600 A
Secondary nominal current:	5 A or 1 A	5 A or 1 A	5 A or 1 A
Nominal frequency:	50 / 60 Hz	50 / 60 Hz	50 / 60 Hz
Transformer accuracy classes:	1; 0.5; 0.5S; 0.2; 0.2S	1; 0.5; 0.5S; 0.2; 0.2S	1; 0.5; 0.5S; 0.2; 0.2S
Optionally for billing purposes:	yes	yes	no
Protection current transformer accuracy classes:	5P5; 5P10; 5P20; 5P30; 10P5; 10P10; 10P20; 10P30	5P5; 5P10; 5P20; 5P30; 10P5; 10P10; 10P20; 10P30	5P5; 5P10; 5P20; 5P30; 10P5; 10P10; 10P20; 10P30
Insulation class:	E	E	E
Cantilever strength:	5000 Nm	5000 Nm	5000 Nm
Weight:	approx. 22 kg	approx. 22 kg	approx. 22 kg

Technical amendments reserved Please note, that the above entries are standard values. Deviating values upon request.



Automatische Mess- und Steuerungstechnik GmbH

Enge Gasse 1 – 91275 Auerbach / Opf. Phone: +49 (0)9643 / 9205-0 Fax: 09643 / 9205-90

www.ams-messtechnik.de info@ams-messtechnik.de

**Dimensional drawings:**

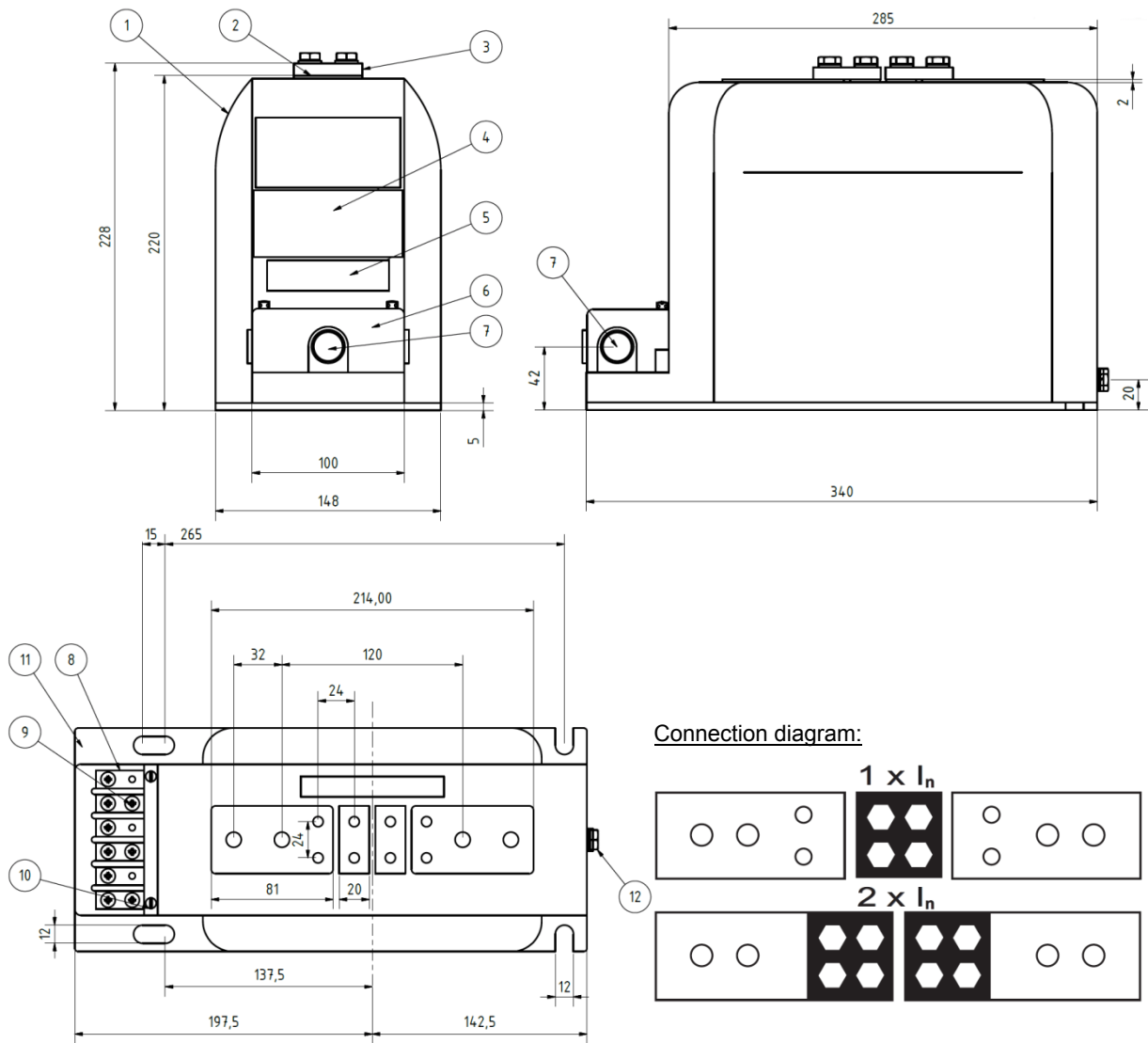

**Key:**

1	Resin body
2	Primary connection M12x23, screws M12x25 (annotation: primary connections also available with a hole interval of 40mm instead of 32 mm)
3	Primary switching connector
4	Power rating plate
5	Warning plate
6	Transparent terminal box cover
7	Cable bushing PG16 (annotation: cable bushing also available with M20x1.5 screw thread upon request.)
8	Max. 6 clamps M5x10, screws M5x12
9	Secondary earth screw, red, M5x15
10	Fastening screws for terminal box cover (sealable for versions approved for billing purposes)
11	Base plate
12	Rear ground connector M8x16

# Support Type Current Transformers

## Support type current transformers for indoor application

7.2 kV, 12 kV and 17.5 kV

7.2 kV and 12 kV available with PTB design permit and legalization



### Description:

Medium voltage current transformers for indoor applications, which transmit one or several network side originating primary currents into standardised secondary currents in a proportional and phase preserving way.

They are encapsulated in polyurethane resin and apart from their primary function as transformer they also serve as collective rail holder.

These current transformers are applicable for measuring purposes as well as for protective purposes; optionally permitted up to 12 kV according to the conformity evaluation procedure for billing purposes.

The medium voltage current transformers are also available as multicore transformers. The possible maximum number of cores depends on the chosen power and accuracy class, which result in the core volume.

### Technical data:

	(E)CTS7,2M12	(E)CTS12M12	CTS17,5M12
Max. operating voltage $U_m$ :	7.2 kV	12 kV	17.5 kV
Rated power frequency withstand voltage:	20 kV	28 kV	38 kV
Rated lightning impulse withstand voltage:	60 kV	75 kV	95 kV
Nominal therm. continuous current $I_{cth}$ :	$1.2 \times I_N$ (up to 2500 A)	$1.2 \times I_N$ (up to 2500 A)	$1.2 \times I_N$ (up to 2500 A)
Nominal therm. short-time current $I_{th}$ :	$100 \times I_N$ , 1 sec.; max. 31.5 kA, 1 sec.	$100 \times I_N$ , 1 sec.; max. 31.5 kA, 1 sec.	$100 \times I_N$ , 1 sec.; max. 31.5 kA, 1 sec.
Rated pulse current $I_{dyn}$ :	$2.5 \times I_{th}$	$2.5 \times I_{th}$	$2.5 \times I_{th}$
Primary nominal current:	$\geq 1500$ A – 3000 A	$\geq 1500$ A – 3000 A	$\geq 1500$ A – 3000 A
Secondary nominal current:	5 A or 1 A	5 A or 1 A	5 A or 1 A
Nominal frequency:	50 / 60 Hz	50 / 60 Hz	50 / 60 Hz
Transformer accuracy classes:	1; 0.5; 0.5S; 0.2; 0.2S	1; 0.5; 0.5S; 0.2; 0.2S	1; 0.5; 0.5S; 0.2; 0.2S
Optionally for billing purposes:	yes	yes	no
Protection current transformer accuracy classes:	5P5; 5P10; 5P20; 5P30; 10P5; 10P10; 10P20; 10P30	5P5; 5P10; 5P20; 5P30; 10P5; 10P10; 10P20; 10P30	5P5; 5P10; 5P20; 5P30; 10P5; 10P10; 10P20; 10P30
Insulation class:	E	E	E
Cantilever strength:	5000 Nm	5000 Nm	5000 Nm
Weight:	approx. 22 kg	approx. 22 kg	approx. 22 kg

Technical amendments reserved Please note, that the above entries are standard values. Deviating values upon request.

**Dimensional drawings:**

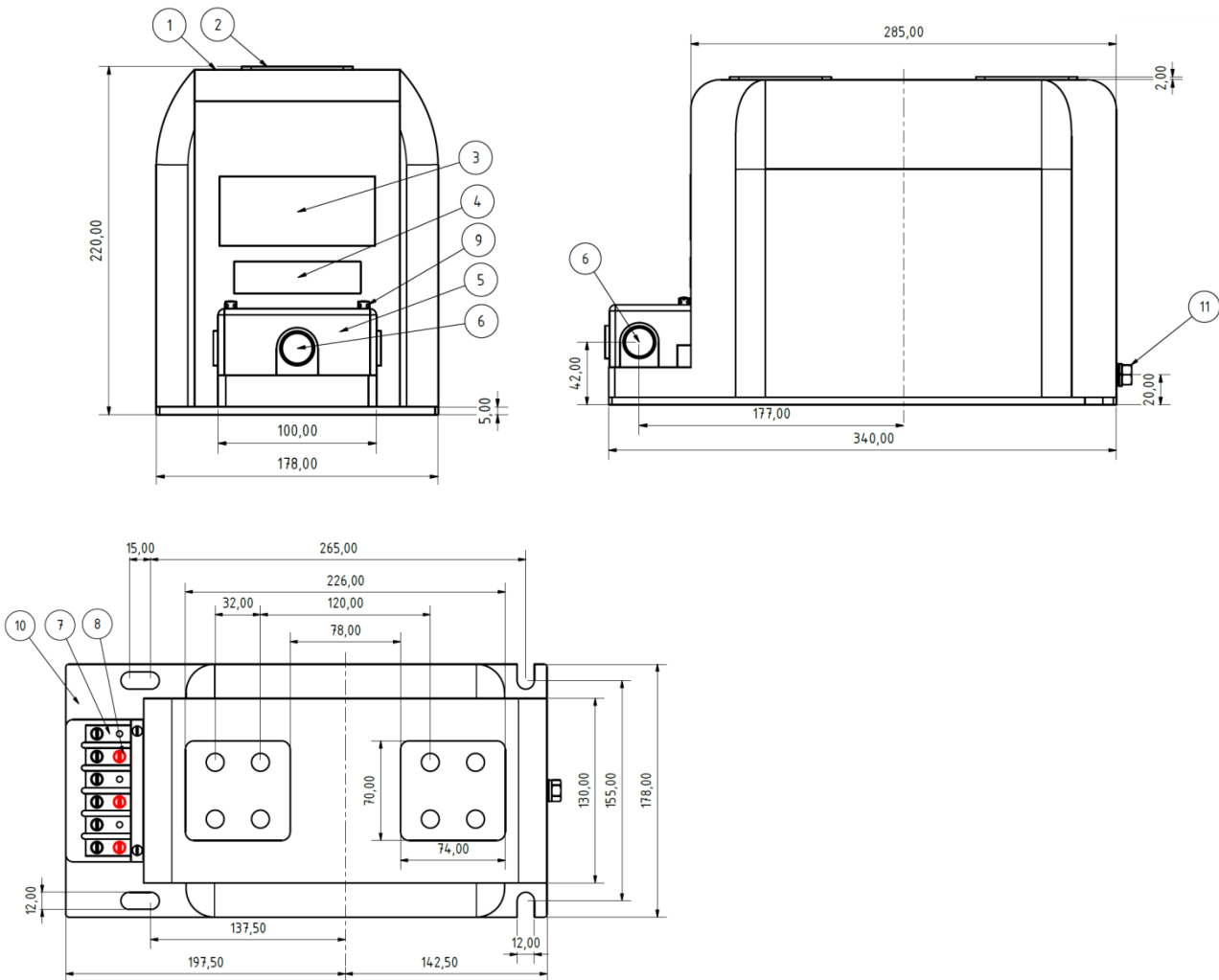

**Key:**

1	Resin body
2	Primary connection M12x23, screws M12x25 (annotation: primary connections also available with a hole interval of 40mm instead of 32 mm)
3	Power rating plate
4	Warning plate
5	Transparent terminal box cover
6	Cable bushing PG16 (annotation: cable bushing also available with M20x1.5 screw thread upon request.)
7	Max. 6 clamps M5x10, screws M5x12
8	Secondary earth screw, red, M5x15
9	Fastening screws for terminal box cover (sealable for versions approved for billing purposes)
10	Base plate
11	Rear ground connector M8x16

# Support Type Current Transformer

**Support type current transformers for indoor application**  
24 kV – narrow design according to DIN 42600, part 8



## Description:

Medium voltage current transformers for indoor applications, which transmit one or several network side originating primary currents into standardised secondary currents in a proportional and phase preserving way.

They are encapsulated in polyurethane resin and apart from their primary function as transformer they also serve as collective rail holder.

These current transformers are applicable for measuring purposes as well as for protective purposes; optionally permitted up to 12 kV according to the conformity evaluation procedure for billing purposes. The medium voltage current transformers are also available as multicore transformers. The possible maximum number of cores depends on the chosen power and accuracy class, which result in the core volume.

## Technical data:

	<b>CTS24M32</b>
Maximum operating voltage $U_m$ :	24 kV
Power frequency withstand voltage:	50 kV
Lightning impulse withstand voltage:	125 kV
Nominal therm. continuous current $I_{cth}$ :	$1.2 \times I_N$ (up to 2500 A)
Nominal therm. short-time current $I_{th}$ :	$100 \times I_N$ , 1 sec.; max. 31.5 kA, 1 sec.
Rated pulse current $I_{dyn}$ :	$2.5 \times I_{th}$
Primary nominal current:	25 A – 3000 A
Secondary nominal current:	5 A or 1 A
Nominal frequency:	50 / 60 Hz
Transformer accuracy classes:	1; 0.5; 0.5S; 0.2; 0.2S
Optional for billing purposes:	yes
Support type current transformer accuracy classes:	5P5; 5P10; 5P20; 5P30; 10P5; 10P10; 10P20; 10P30
Insulation class:	E
Cantilever strength:	5000 Nm
Weight:	approx. 28 kg

Technical amendments reserved Please note, that the above entries are standard values. Deviating values upon request.

## Dimensional drawings:

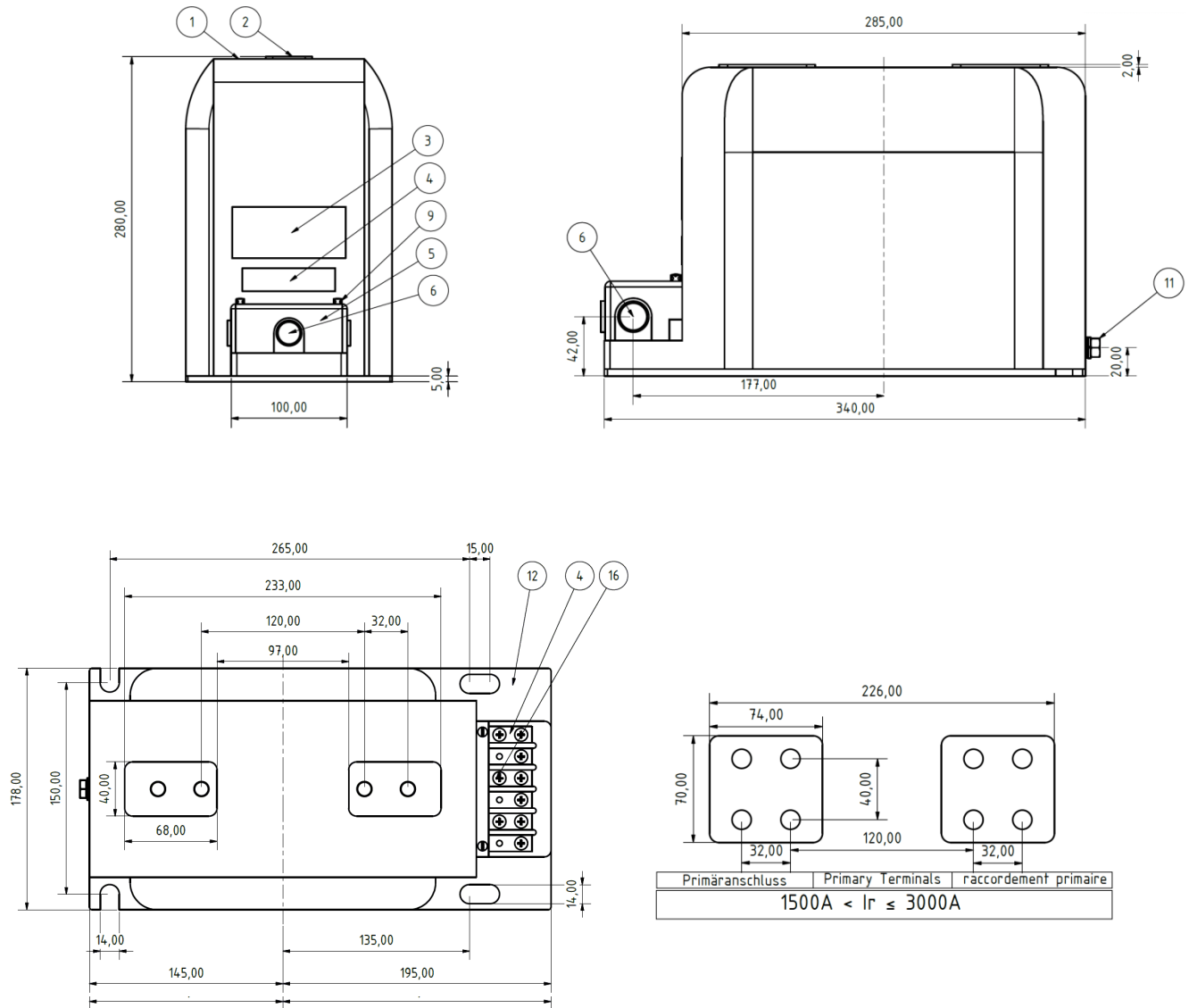

## Key:

1	Resin body
2	Primary connection M12x23, screws M12x25 (annotation: primary connections also available with a hole interval of 40mm instead of 32 mm)
3	Power rating plate
4	Warning plate
5	Transparent terminal box cover
6	Cable bushing PG16 (annotation: cable bushing also available with M20x1.5 screw thread upon request.)
7	Max. 6 clamps M5x10, screws M5x12
8	Secondary earth screw, red, M5x15
9	Fastening screws for terminal box cover (sealable for versions approved for billing purposes)
10	Base plate
11	Rear ground connector M8x16

# Fully Encapsulated Current Transformers

## Fully encapsulated split core current transformers for indoor application 0.72 kV / 1.2 kV

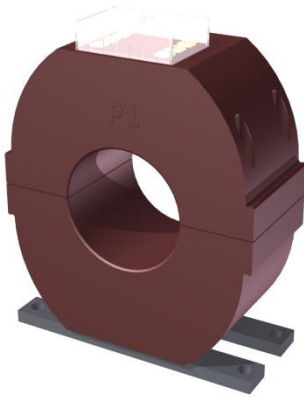

### Characteristics / Benefit

Split core current transformers are suitable for measuring purposes as well as for protective purposes.

The modular structure of this device series enables a large number of variations within the individual sizes (e.g. two cores within one device). Please see next page for details concerning the frame sizes.

Nominal voltage: 0.72/3/- kV or 1.2/6/- kV; with corresponding insulation, the transformer can also be applied above the 0.72 kV respectively 1.2 kV.

Primary current ranges: 50 A ... 5000 A

Secondary currents: 1 A, 2 A oder 5 A

Nominal power: 2,5 VA ... 30 VA

Transformer accuracy classes 0.2S; 0.2; 0.5S; 0.5; 1; 3

Overcurrent limiting factor for measuring cores: FS5 or FS10

Protection current transformer accuracy classes: 5P / 10P / PX

Accuracy limiting factor for protection cores: 5, 10, 15, 20, 3

### CTO split core current transformers

#### Dimensions:

Primary conductor diameter: max. 360 mm  
Overall width: 150 - 500 mm  
Overall depth: 60 - 300 mm

Details concerning the dimensions can be seen on the next page

#### Technical data:

Rated therm. continuous current  $I_{cth}$ :  $1.0 \times I_N$  or  $1.2 \times I_N$ , other values on request  
Rated therm. short-time current  $I_{th}$ : Min.  $100 \times I_N / 1 \text{ sec.}$ , other values on request  
Rated dynamic pulse current  $I_{dyn}$ :  $2.5 \times I_{th}$   
Max. operating voltage  $U_m$ : 0.72 kV or 1.2 kV  
Insulation test voltage: 3 kV,  $U_{eff}$ , 50 Hz, 1 min. or 6 kV,  $U_{eff}$ , 50 Hz, 1 min.  
Nominal frequency: 50 Hz or 60 Hz, other values on request  
Insulation class: E  
Applied technical standards: DIN EN 61869, part 1 + 2 (formerly DIN EN 60044-1)

#### Further information:

- Split core current transformer fully encapsulated in polyurethane
- The current transformers type CTO are designated for the afterwards installation into already existing low voltage power switching stations. Furthermore, there are operators applying this current transformer with corresponding insulation of the primary conductor also in medium voltage power switching stations. Further areas of operation are wind power stations, energy generation systems on ships, energy distribution systems ...
- The two halves of the current transformer are held together by means of four screws with compression springs or spring clamps on the sides, ensuring an equal contact pressure of both of the halves.
- The secondary connections are equipped with M5 screws at factory. A transparent cover cap serves as contact protection.
- Protection type: housing: IP54, terminal cover: IP20
- Working temperature range:  $-5^\circ\text{C} < T < +40^\circ\text{C}$
- Storage temperature range:  $-25^\circ\text{C} < T < +70^\circ\text{C}$
- Transformer mounting by means of base plates attached to the resin body
- Packaging unit: 1 piece
- Customs tariff number: 85043129



## Dimensional drawings:

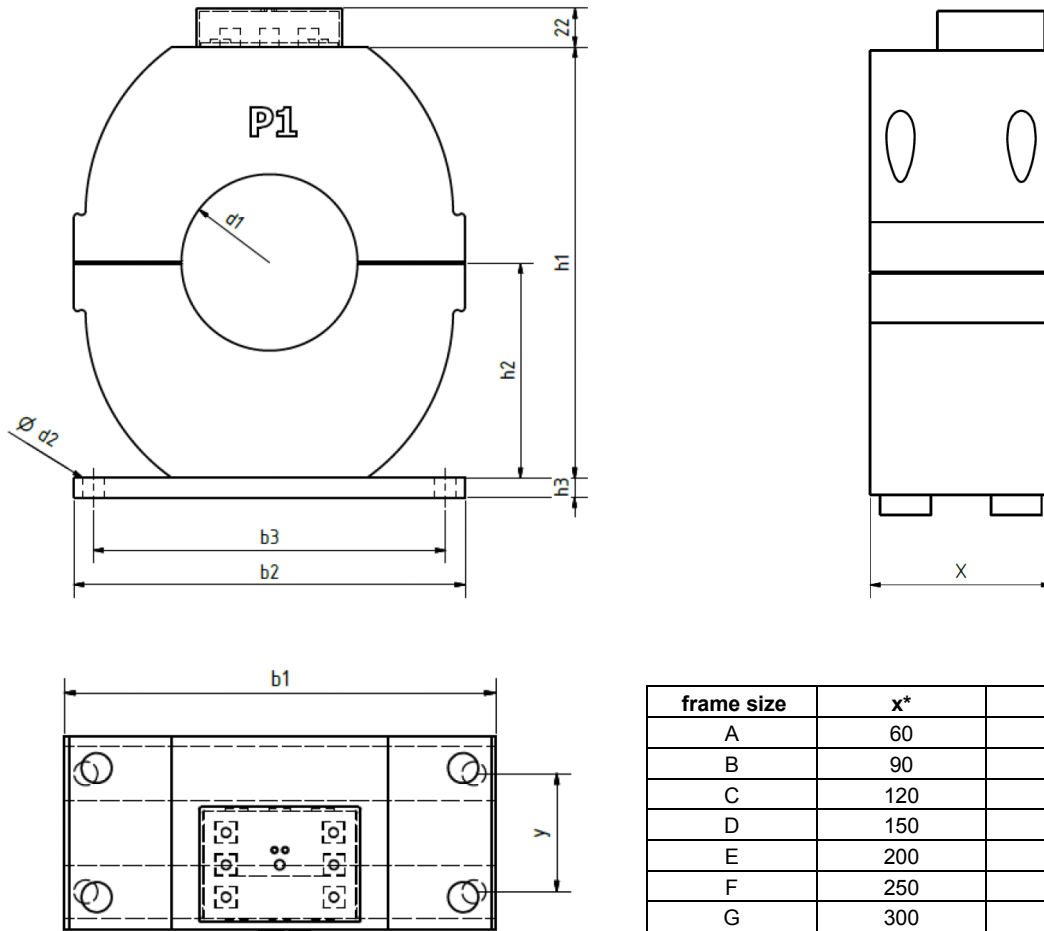

\*dimension x + y dependent on type and number of installed measuring systems.

## Determination of the transformer characterization:

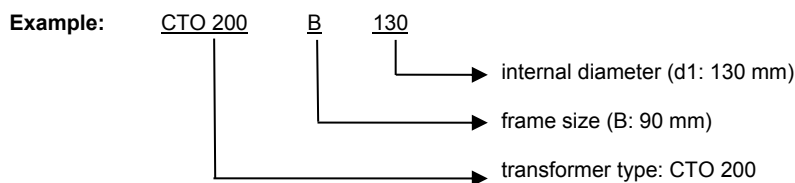

transformer type	b1	b2	b3	max. d1	d2	h1	h2	h3	max. frame size	available
CTO 135	135	150	130	90	9	150	75	10	C	on request
CTO 150	150	150	130	110	9	165	82.5	10	D	on request
CTO 170	170	170	150	110	11	185	97.5	10	D	yes
CTO 200	200	200	180	140	11	220	110	10	E	yes
CTO 250	250	250	230	150	11	270	135	10	E	yes
CTO 300	300	300	280	210	11	330	165	10	F	yes
CTO 350	350	350	330	250	11	380	190	10	F	on request
CTO 400	400	400	370	300	13	430	215	15	G	on request
CTO 500	500	500	440	360	13	530	265	15	G	on request

# Voltage Transformers

## Voltage transformer for indoor application

7.2 kV; 12 kV; 17.5 kV and 24 kV – narrow, small and large design according to DIN 42600, part 9 respectively part 7 or part 3



Apart from our medium-voltage current transformers, we can also gladly provide you with suitable voltage converters for voltage levels from 7.2 kV to 24 kV inclusively.

These are available unipolarly as well as bipolarly insulated and can be applied for measuring purposes as well as for protective purposes. The unipolarly insulated voltage transformers can optionally also be equipped for earth fault by means of an additional winding.

We thereby cover all demands for typical medium-voltage switching systems.

## Notes

# Request Form

Your request / order:

**Company:** \_\_\_\_\_

**Address:** \_\_\_\_\_

\_\_\_\_\_

**Contact person:** \_\_\_\_\_

**Phone:** \_\_\_\_\_

**E-mail address:** \_\_\_\_\_

Request

Order

	Pos. 1	Pos. 2	Pos. 3
<b>Quantity:</b>	_____	_____	_____
<b>Conversion:</b>	_____	_____	_____
<b>Core 1:</b> (power and class)	_____	_____	_____
<b>Core 2:</b> (optional) (power and class)	_____	_____	_____
<b>Core 3:</b> (optional) (power and class)	_____	_____	_____
<b>Insulation level:</b> (e.g. 12/28/75 kV)	_____	_____	_____

We ask you to indicate values deviating from our standard values hereinafter:  
(e.g. nominal therm. short-time current I<sub>th</sub> of 20 kA instead of 31.5 kA; frequency of 60 Hz instead of 50 Hz etc.)

\_\_\_\_\_

\_\_\_\_\_

\_\_\_\_\_

KA\_Mittelspannung-0204-2019-GB



Automatische Mess- und Steuerungstechnik GmbH

91275 Auerbach – Enge Gasse 1    Phone 0 96 43/92 05 - 0    Internet: [www.ams-messtechnik.de](http://www.ams-messtechnik.de)  
91270 Auerbach – Postfach 1180    Fax. 0 96 43/92 05 - 90    E-mail: [info@ams-messtechnik.de](mailto:info@ams-messtechnik.de)