

ams[®]

Measuring Technology...

analogue and digital

Our Experience
Is Your Success

SHUNTS



Development
Production
Sales
Tradition



Your success
is important to us!
...that's what we stand for!



analogue and digital
measuring technology

current transformers
energy management

shunts
transducers

gas warning systems

bus bar insulators and supports

laboratory &
teaching aids

services



Shunts

The long-life shunts of the AMS GmbH are used to expand the current measuring range of moving coil ammeters for the reliable displaying and further processing of direct currents, especially at high rates of up to 15,000A.

The direct current flowing through the shunt generates a proportional voltage drop which, for example, can be displayed by means of a moving coil meter connected in parallel or be further processed electronically.

The shunts manufactured by us comply with DIN 43703 and DIN EN 60051.

The accuracy is 0.5% relative to the nominal value. In addition, shunts with an increased accuracy of 0.2% or 0.1% can be realised on request.

The rated currents are in the range of 1A to 15,000A. Shunts are manufactured in three different designs, depending on the nominal current.

Up to 25A, the shunts are always mounted on an insulating base which can be mounted on a 35mm DIN rail or by means of screw fixing. Above 25A, an insulating base is optionally available for type A, as well as for some current ranges in type B.

Voltage drops of 60mV, 100mV, 150mV and 300mV are available. Deviating values can also be realised on customer request.

Operating conditions:

- ▶ working temperature: $-10 \leq \vartheta \leq +55 \text{ }^\circ\text{C}$
- ▶ storage temperature: $-25 \leq \vartheta \leq +65 \text{ }^\circ\text{C}$
- ▶ relative humidity: $\leq 75 \%$ (no condensation)
- ▶ climatic conditions: climatic class 3 according to VDE/VDI 3540

Accuracy:

- ▶ accuracy class: class 0.5 (optional class 0.2 or 0.1)

Material:

- ▶ resistor: Manganin
- ▶ connector, type A: brass
- ▶ connector, type B: brass/copper
- ▶ connector, type C: copper

Connections:

- ▶ current path: see dimension drawings
- ▶ voltage path: M5 x 8

Safety:

- ▶ protection class: IP00

Connector shape:

- ▶ type A: flat profile, with insulating base (1 ... 25A)
flat profile, optionally with insulating base (30 ... 400A)
- ▶ type B: L-section
- ▶ type C: T-section

Applied standards:

- ▶ DIN 43703 shunt dimensions
- ▶ DIN EN 60051 direct acting indicating analogue electrical measuring instruments and their accessories

Standard designs

- ▶ voltage drop: 60mV; 100mV; 150mV; 300mV
- ▶ overload withstand: 1.2 rated current, permanently 5-fold, max. 5 sec. ($\leq 2,000\text{A}$)
2-fold, max. 5 Sek. ($> 2,000\text{A}$... 10,000A)
- ▶ rated current: 1 ... 15000A
- ▶ accuracy: class 0,5
- ▶ insulating base: 1... 25A as standard
30...400A optionally
- ▶ cover cap available as accessory: 1...400A (60mV)

Special designs

A flexible manufacturing allows the realisation of individually customised shunts.

- ▶ different voltage drop
- ▶ different rated current
- ▶ accuracy class 0.2, 0.1 on request
- ▶ customised designs according to dimensioned drawing for your installation situation

Ordering example

- ▶ voltage drop: 60mV
- ▶ rated current: 1000A
- ▶ accuracy class: 0.5

Dimension Drawings

Type A

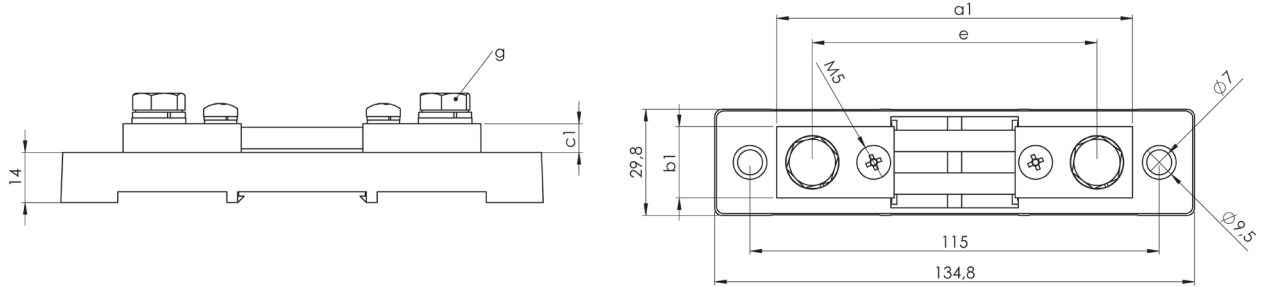

Type B

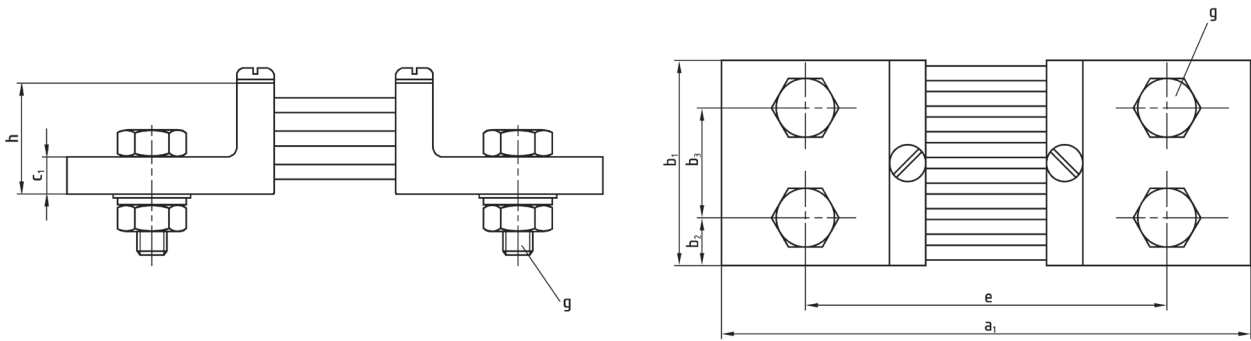

Type C

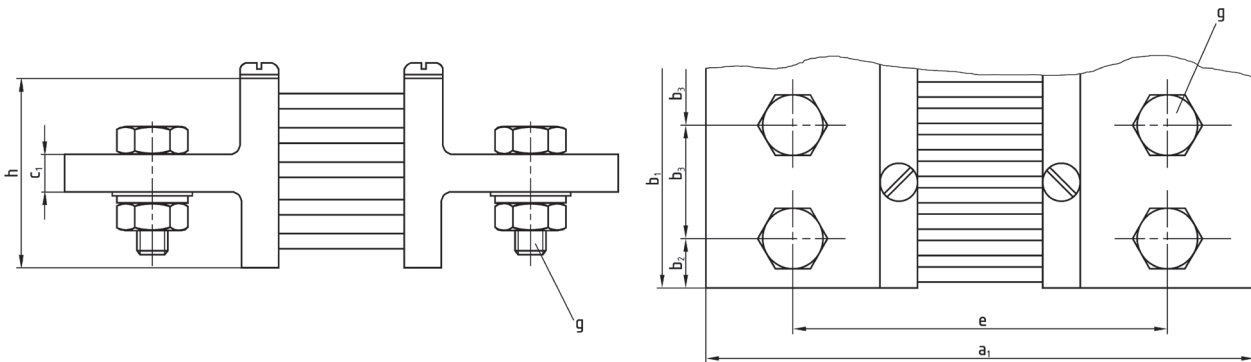

Dimensions

voltage drop [mV]	dim. [mm]	for rated current [A]													
		1 - 25	30 - 250	300- 400	200- 350	400- 800	900- 1000	1000- 1250	1500- 2000	2500- 3000	3000- 5000	6000- 8000	8000- 10000	15000	
60		type A			type B						type C				
	a ₁	90	100		145			165			165	175	185		
	b ₁	20		30	30	40	60		90	120	120	154	206	310	
	b ₂	-			15	20	30		21	30	30	25			
	b ₃	-			-				48	60	60	52			
	c ₁	8		10	10						15	25	30		
	e	78	80		105			115			115	125	135		
	h	-			30						60	130	170		
100		type A			type B						type C				
	a ₁	90	145	/	190			210			210	220		/	
	b ₁	20	25		30	40	60		120	120		154			
	b ₂	-			15	20	30		30		25				
	b ₃	-			-				60	60	52				
	c ₁	8			10						15	25			
	e	78	125		150			160			160	170			
	h	-			30						60	130			
150		type A			type B						type C				
	a ₁	90	225		270			290			290		300	310	
	b ₁	20	25		30	40	70		90	120		154	206	310	
	b ₂	-			15	20	35		21	30	25				
	b ₃	-			-				48	60	52				
	c ₁	8		10						15	25		30		
	e	78	205		230			240			240	250		260	
	h	-			50			60			60	130		170	
300		type A			type B						type C				
	a ₁	90	384		429			449			449		459		/
	b ₁	20	25		30	40	70		90	120		154			
	b ₂	-			15	20	35		21	30	25				
	b ₃	-			-				48	60	52				
	c ₁	8		10						15	25				
	e	78	364		389			399			399	409			
	h	-			50			60			60	130			

Subject to change

Type A



Voltage drop 60 mV - class 0.5

rated current [A]	insulating base*	weight (approx.)	current connection (dimension g)	number of connections
1	yes	0.10 kg	M5x12	2 x 1
1.5	yes	0.10 kg	M5x12	2 x 1
2.5	yes	0.10 kg	M5x12	2 x 1
4	yes	0.10 kg	M5x12	2 x 1
6	yes	0.10 kg	M5x12	2 x 1
10	yes	0.10 kg	M5x12	2 x 1
15	yes	0.11 kg	M5x12	2 x 1
25	yes	0.11 kg	M5x12	2 x 1
40	optional	0.12 kg	M8x16	2 x 1
50	optional	0.12 kg	M8x16	2 x 1
60	optional	0.13 kg	M8x16	2 x 1
80	optional	0.13 kg	M8x16	2 x 1
100	optional	0.13 kg	M8x16	2 x 1
150	optional	0.13 kg	M8x16	2 x 1
200	optional	0.13 kg	M8x16	2 x 1
250	optional	0.13 kg	M8x16	2 x 1
300	optional	0.21 kg	M10x20	2 x 1
400	optional	0.21 kg	M10x20	2 x 1

*cover cap available as accessory for voltage drop 60mV

Voltage drop 100 mV - class 0.5

rated current [A]	insulating base*	weight (approx.)	current connection (dimension g)	number of connections
1	yes	0.10 kg	M5x12	2 x 1
1.5	yes	0.10 kg	M5x12	2 x 1
2.5	yes	0.10 kg	M5x12	2 x 1
4	yes	0.10 kg	M5x12	2 x 1
6	yes	0.10 kg	M5x12	2 x 1
10	yes	0.11 kg	M5x12	2 x 1
15	yes	0.11 kg	M5x12	2 x 1
25	yes	0.11 kg	M5x12	2 x 1
40	optional	0.16 kg	M8x16	2 x 1
50	optional	0.16 kg	M8x16	2 x 1
60	optional	0.16 kg	M8x16	2 x 1
80	optional	0.16 kg	M8x16	2 x 1
100	optional	0.17 kg	M8x16	2 x 1
150	optional	0.18 kg	M8x16	2 x 1
200	optional	0.18 kg	M8x16	2 x 1
250	optional	0.18 kg	M8x16	2 x 1

*cover cap available as accessory for up to 25A/100mV

Voltage drop 150 mV - class 0.5

rated current [A]	insulating base*	weight (approx.)	current connection (dimension g)	number of connections
1	yes	0.10 kg	M5x12	2 x 1
1.5	yes	0.10 kg	M5x12	2 x 1
2.5	yes	0.11 kg	M5x12	2 x 1
4	yes	0.11 kg	M5x12	2 x 1
6	yes	0.11 kg	M5x12	2 x 1
10	yes	0.11 kg	M5x12	2 x 1
15	yes	0.11 kg	M5x12	2 x 1
25	yes	0.12 kg	M5x12	2 x 1
40	optional	0.17 kg	M8x16	2 x 1
50	optional	0.17 kg	M8x16	2 x 1
60	optional	0.18 kg	M8x16	2 x 1
80	optional	0.19 kg	M8x16	2 x 1
100	optional	0.21 kg	M8x16	2 x 1
150	optional	0.24 kg	M8x16	2 x 1
200	optional	0.24 kg	M8x16	2 x 1
250	optional	0.26 kg	M8x16	2 x 1

*cover cap available as accessory for up to 25A/150mV

Voltage drop 300 mV - class 0.5

rated current [A]	insulating base	weight (approx.)	current connection (dimension g)	number of connections
1	yes	0.11 kg	M5x12	2 x 1
1.5	yes	0.11 kg	M5x12	2 x 1
2.5	yes	0.11 kg	M5x12	2 x 1
4	yes	0.11 kg	M5x12	2 x 1
6	yes	0.11 kg	M5x12	2 x 1
10	yes	0.11 kg	M5x12	2 x 1
15	yes	0.12 kg	M5x12	2 x 1
25	yes	0.13 kg	M5x12	2 x 1
40	optional	0.19 kg	M8x16	2 x 1
50	optional	0.19 kg	M8x16	2 x 1
60	optional	0.22 kg	M8x16	2 x 1
80	optional	0.24 kg	M8x16	2 x 1
100	optional	0.27 kg	M8x16	2 x 1
150	optional	0.33 kg	M8x16	2 x 1
200	optional	0.33 kg	M8x16	2 x 1
250	optional	0.33 kg	M8x16	2 x 1



Type B



Voltage drop 60 mV - class 0.5

rated current [A]	insulating base	weight (approx.)	current connection (dimension g)	number of connections
250	optional	0.5 kg	M12x40	2 x 1
400	optional	0.8 kg	M16x45	2 x 1
600	optional	0.8 kg	M16x45	2 x 1
1000	no	1.4 kg	M20x50	2 x 1
1500	optional	2.0 kg	M16x45	2 x 2
2500	no	2.9 kg	M20x50	2 x 2

Voltage drop 100 mV - class 0.5

rated current [A]	insulating base	weight (approx.)	current connection (dimension g)	number of connections
250	optional	0.6 kg	M12x40	2 x 1
400	optional	0.9 kg	M16x45	2 x 1
600	optional	0.9 kg	M16x45	2 x 1
1000	no	1.6 kg	M20x50	2 x 1
1500	optional	3.1 kg	M16x45	2 x 2

Voltage drop 150 mV - class 0.5

rated current [A]	insulating base	weight (approx.)	current connection (dimension g)	number of connections
250	optional	0.8 kg	M12x40	2 x 1
400	optional	1.2 kg	M16x45	2 x 1
600	optional	1.3 kg	M16x45	2 x 1
1000	no	2.5 kg	M20x50	2 x 1

Voltage drop 300 mV - class 0.5

rated current [A]	insulating base	weight (approx.)	current connection (dimension g)	number of connections
250	optional	0.9 kg	M12x40	2 x 1
400	optional	1.4 kg	M16x45	2 x 1
600	optional	1.7 kg	M16x45	2 x 1
1000	no	3.1 kg	M20x50	2 x 1

Type B



Voltage drop 60 mV - class 0.5

rated current [A]	insulating base	weight (approx.)	current connection (dimension g)	number of connections
4000	no	4.3 kg	M20x60	2 x 2
6000	no	10.9 kg	M20x75	2 x 3
10000	no	21.1 kg	M20x80	2 x 4
15000	no	31.7 kg	M20x80	2 x 6

Voltage drop 100 mV - class 0.5

rated current [A]	insulating base	weight (approx.)	current connection (dimension g)	number of connections
2500	no	4.6 kg	M20x60	2 x 2
4000	no	8.9 kg	M20x75	2 x 2
6000	no	11.9 kg	M20x75	2 x 3

Voltage drop 150 mV - class 0.5

rated current [A]	insulating base	weight (approx.)	current connection (dimension g)	number of connections
1500	no	3.8 kg	M16x60	2 x 2
2500	no	5.5 kg	M20x60	2 x 2
4000	no	10.0 kg	M20x75	2 x 2
6000	no	14.2 kg	M20x75	2 x 3
10000	no	26.5 kg	M20x80	2 x 4

Voltage drop 300 mV - class 0.5

rated current [A]	insulating base	weight (approx.)	current connection (dimension g)	number of connections
1500	no	4.7 kg	M16x60	2 x 2
2500	no	7.1 kg	M20x60	2 x 2
4000	no	13.0 kg	M20x75	2 x 2
6000	no	17.6 kg	M20x75	2 x 3

Special type shunt

Apart from the production of standard shunts according to DIN 43703 and DIN EN 60051 we are also able to manufacture shunts in accordance with predefined customer specification. This applies to special electrical values at nominal current as well as for special values at voltage drop.

Due to our established machine shops, we are as well able to produce special types regarding the dimension and construction design of a shunt in accordance with individual customer specification. Ideally, this will be carried out according to a customer-provided template. We also willingly perform the sizing and design of a special type shunt in accordance with your specifications regarding electrical performance ratings and constructional needs. In our design department, we draw up a 3-D scale drawing on CAD.

Development and production from a single source.

In the framework of new development projects, we willingly elaborate the custom special type shunt in accordance with your specifications, together with you. Based on our longtime expertise in the field of shunt production, we are therefore the ideal partner for you. In our in-house production shop, we go along with you from the design via the production of the first prototype through to serial production. Everything from a single source in the premises of AMS!

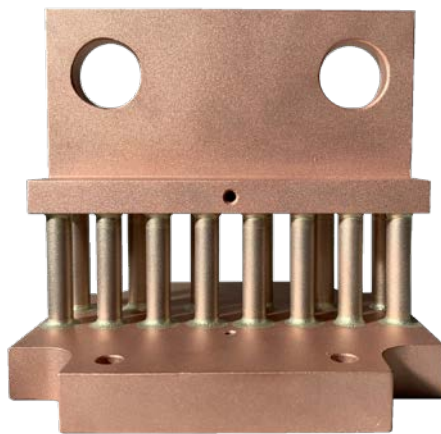

Producing a special shunt according to provided drawings:

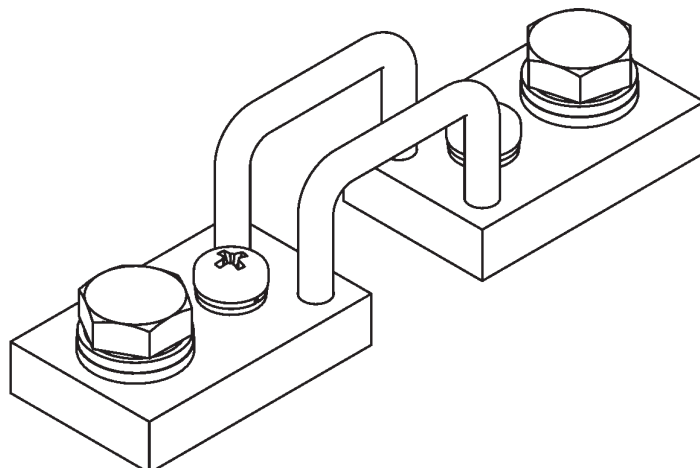

Special type shunts

Due to the flexible production setup, an implementation of individual customer requirements is possible.

- ▶ divergent voltage drops
- ▶ divergent nominal current
- ▶ accuracy classes 0.2 and 0.1
- ▶ design types according to dimensional drawing for your mounting conditions

- ▷ shunts can be produced as any special type
- ▷ special shunts can be produced in accuracy class 0.5 as well as 0.2 (0.1 on request).
- ▷ construction according to your specifications
- ▷ monitoring of a new development

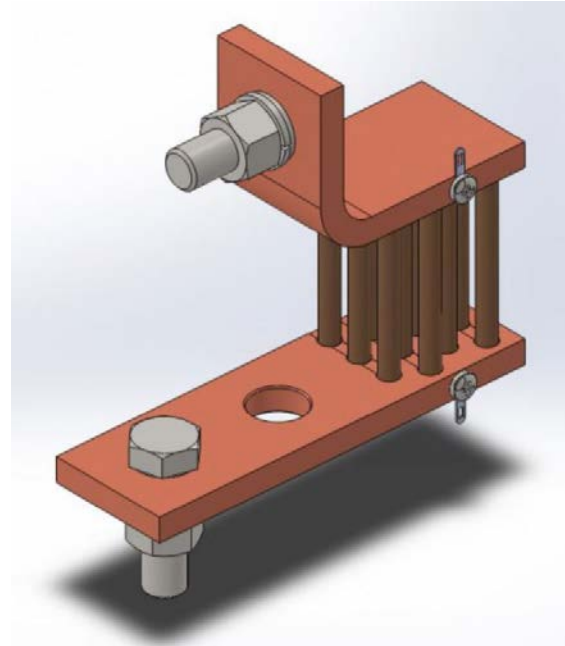

The durable shunts of AMS GmbH conduce to the extension of the measuring range of moving-coil meters, to the reliable indication and processing of direct currents, especially at high values. The direct current flowing through the shunt generates a proportional voltage drop, which can for example be displayed or electronically processed by means of a moving-coil measuring instrument connected in parallel.

„Our Experience Is Your Success!“

The AMS Messtechnik GmbH is an approved company of great tradition. We develop, manufacture and distribute high quality measuring instruments and electronic components for industries as well as gas detectors for private homes and camping.



**Development
Production
Sales
Tradition**



We make high currents measurable.

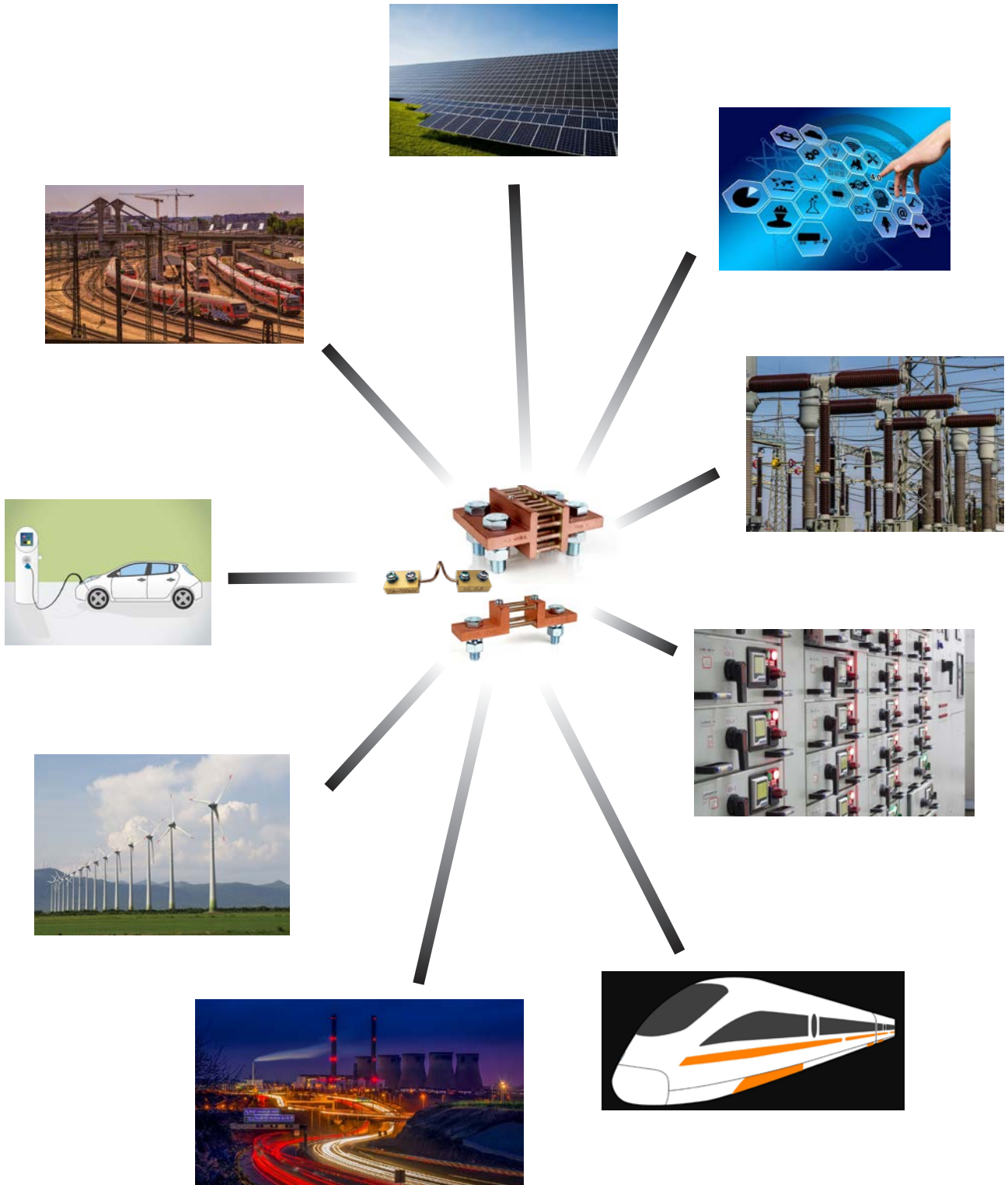

The logo for AMS, consisting of the lowercase letters 'ams' in a bold, sans-serif font, followed by a registered trademark symbol (®).

ams[®]

**Automatische Mess-
und Steuerungstechnik GmbH**

**Enge Gasse 1
91275 Auerbach**

Tel. +49 9643 / 92 05-0

Fax: +49 9643 / 92 05 90

Email: info@ams-messtechnik.de

Internet: www.ams-messtechnik.de